

QuickSwitch® Model 6195 All-Optic SC Duplex A/B/C/D Switch with Serial Remote Control

- **Ideal for secure systems and networks applications.**

INTRODUCTION

The QuickSwitch® 6195 SC Duplex A/B/C/D Switch allows a fiber optic device connected to the SC duplex COMMON connector of the unit to access any of four fiber optic networks connected to the A, B, C, or D ports. The switch position can be changed either by the front panel pushbutton, or by a device connected to the Remote port located on the rear panel.

Remote access can be accomplished by RS232 commands sent via the Remote Serial Port. Users can remotely monitor status and control switch functions. The QuickSwitch® 6195 is enclosed in a 1U, full rack size, all metal black chassis designed to fit in a standard 19" rack.

FEATURES:

- Access any one of four separate fiber optic networks from one computer.
- The switch ports are transparent to all data.
- **All fiber signals are switched via break-before-make MEMS-based mirror/prism switch technology and supports Gigabit data rates.**
- Front panel pushbutton control.
- Retains last switch position in the event of power loss and continues to pass data.
- When power is restored, unit will power up in the "A" position.
- Remote Control RS232 ASCII command interface that allows the user to control switch position, lockout front panel operations, obtain switch status, as well as, query firmware version number, query serial number and enable/disable autosend of switch positions.
- Front panel LED's display the present position and power status.
- All A, B, C, D, and COM ports are SC duplex, Multi-mode, 50/125 micron, and support a wavelength of 850nm.
- The fiber ports are configured per TIA/EIA-568-B.3, where the TX of the COM port is routed to the RX of the A/B ports and vice versa.
- Custom length rigorously tested and certified SC fiber optic cables available for your switch installation.
- ★ **Municipalities, schools, government: This product is on GSA Schedule!**



SPECIFICATIONS:

PORT CONNECTORS: (5) SC Duplex Fiber Optic connectors labeled A, B,C, D, and COMMON.

FRONT PANEL CONTROLS: (1) pushbutton allows local switching.

DISPLAY: (4) Front panel LED's display switch position and power status.

REMOTE: (1) DB9 female connector on rear panel accepts ASCII RS232 Serial Data for Remote Control operation.

POWER: UL approved 100VAC-240VAC, 50Hz-60Hz wall mount power module supplies 12 VDC, 500mA to the unit. Has 2-prong, US, non-polarized plug.

FIBER SIZE: 50/125 micron.

WAVELENGTH: 850 nm.

DIMENSIONS: 19" W x 1.75" H x 8.82" D.
(48.3 x 4.5 x 22.5 cm)

WEIGHT: Approximately 4.7 lbs. (2.2 kg)

WIDE RANGE POWER OPTION AVAILABLE:

(Cat No 517277) **CE, RoHS, and UL** listed table mount power module, 100VAC-240VAC, 50Hz-60Hz for use in place of standard power module that is included with the unit. Has IEC 60320 C14 inlet. **Ideal for internal applications.**

QuickSwitch® 6195 A/B/C/D Network Transfer Application

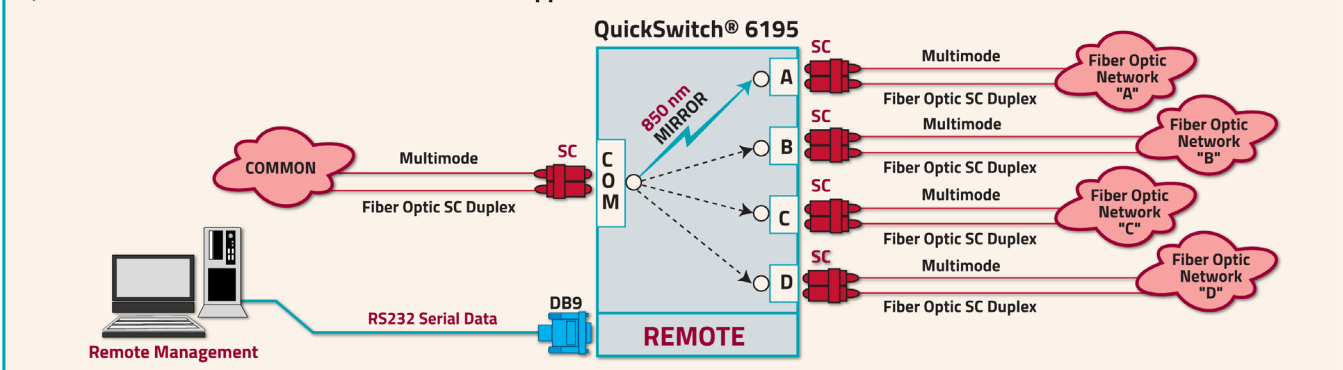

Custom Fabricated Fiber Optic Cables For Your Network Switch Installation.

- ESL Custom Fabricated Fiber Optic Cable Assemblies are of the highest quality available.
- All Cables are expertly polished and 100% tested for low insertion loss and back reflection.
- These custom cables use the highest quality fiber optic cable material and our connectors are all brand name connectors, AMP, Molex, Siecor.
- Our cable assembly clean room is designed for quick turn-around for standard or special requirements.
- We have a specially trained team of dedicated experienced assemblers ready to meet all your requirements.

To Order Fiber Optic Cables

- **By Phone:** Call 1-401-943-1164 for technical assistance.
- **On Line:** <http://www.electrostandards.com/Products-Custom/Fiber-Optic-Cable/>
- **By Fax:** Please fill out form completely and fax to Electro Standards Laboratories at 1-401-946-5790. If you need assistance please don't hesitate to call us.



Scan QR code:
For Online
Fiber Optic Cable Form

Select your "A" and "B" connector type by placing a check mark next to the appropriate connector, then select the appropriate categories for your fiber optic cable requirement.

Connector "A" Information
TYPE <input type="checkbox"/> ST <input type="checkbox"/> SC <input type="checkbox"/> SC Duplex <input type="checkbox"/> FC <input type="checkbox"/> FDDI <input type="checkbox"/> ESCON <input type="checkbox"/> LC <input type="checkbox"/> MTRJ <input type="checkbox"/> MTP <input type="checkbox"/> MTP θ 1x12 θ 2x12 θ 3x12 <input type="checkbox"/> SMA905 <input type="checkbox"/> SMA906 <input type="checkbox"/> NONE (Pigtail) <input type="checkbox"/> Other _____
Polarity <input type="checkbox"/> Female <input type="checkbox"/> Male

Connector "B" Information
TYPE <input type="checkbox"/> ST <input type="checkbox"/> SC <input type="checkbox"/> SC Duplex <input type="checkbox"/> FC <input type="checkbox"/> FDDI <input type="checkbox"/> ESCON <input type="checkbox"/> LC <input type="checkbox"/> MTRJ <input type="checkbox"/> MTP <input type="checkbox"/> MTP θ 1x12 θ 2x12 θ 3x12 <input type="checkbox"/> SMA905 <input type="checkbox"/> SMA906 <input type="checkbox"/> NONE (Pigtail) <input type="checkbox"/> Other _____
Polarity <input type="checkbox"/> Female <input type="checkbox"/> Male

Length _____ <input type="checkbox"/> in Meters <input type="checkbox"/> in Feet Mode <input type="checkbox"/> Single Mode <input type="checkbox"/> Multimode Fire Rating <input type="checkbox"/> PVC Riser <input type="checkbox"/> Plenum Core Size <input type="checkbox"/> 50/125mm <input type="checkbox"/> 62.5/125mm <input type="checkbox"/> 9/125mm <input type="checkbox"/> Other _____ Cable Type <input type="checkbox"/> Simplex <input type="checkbox"/> Duplex <input type="checkbox"/> Breakout <input type="checkbox"/> Distribution <input type="checkbox"/> Other _____

Name _____	Phone _____
Title _____	Fax _____
Company _____	P.O. # _____
Address _____	Quantity _____
State _____ Zip _____	Date _____ Ref.# _____
Email _____	Total # of pgs. Faxed _____

