

PathWay® Model 7377 Single Channel Cat6A RJ45 A/B Switch, with SSH, HTTPS GUI and SNMPv2

Utilizes High Performance Shielded RJ45 Connectors.

INTRODUCTION

The PathWay® Model 7377 Single Channel RJ45 Cat6A A/B Switch with SSH and HTTPS GUI allows the user the capability of sharing a single port interface device, connected to the "COMMON" port, among two other devices, connected to the "A" and "B" ports. Remote Control access can be accomplished using an Ethernet 10/100BASE-T connection and either SSH commands or a secure Graphical User Interface. The Model 7377 is enclosed in a 1U, full rack size, all metal black chassis designed to provide EMI/RFI shielding.

FEATURES:

- Allows access to two RJ45 Cat6A interface networks from one COMMON RJ45 Cat6A interface network or device.
- The switch ports are transparent to all data.
- All (8) pins of the RJ45 interface are switched via break before-make electromechanical relays.
- Maintains last position on power loss and continues to pass data. Powers up in last position.
- Certified for Cat6A compliance.**
- Front panel pushbutton control.
- Control of the switch position from a 10/100Base-T LAN Ethernet environment.
- Remote Control SSH Command Interface or Graphical User Interface that allows the user to control switch position, lockout front panel operations, and obtain switch status.
- Remote control of the switch is secured by user login with password protection and TLS/SSL cryptographic protocols.
- SNMPv2 support service responds to SNMP requests and generates SNMP traps. SNMP supports setting of read community, write community, system information (Contact, Name, Description, & Location) as well as trap destinations (primary & secondary).
- SNMP traps for Cold Start and Linkdown are sent on unit boot up and when Remote Module is rebooted through Graphical User Interface.
- The XPort Pro device server supports SSLv3 and its successors, TLS1.0 and TLS1.1. An incoming SSLv2 connection attempt is answered with an SSLv3 response. If the initiator also supports SSLv3, SSLv3 handles the rest of the connection.



SPECIFICATIONS:

PORT CONNECTORS: (3) RJ45(F) shielded connectors, A, B, and COMMON.

COMPLIANCE: Interface meets or exceeds Cat 6A performance.

CONTROLS: (1) Pushbutton to select A or B.

DISPLAY: (2) Red LED's display switch position and indicate power presence.

REMOTE CONTROL: (1) RJ45 female connector on rear panel accepts Ethernet 10/100Base-T connection and either SSH commands or a secure Graphical User Interface for remote operation.

POWER: UL approved 100VAC-240VAC, 50Hz-60Hz wall mount power module supplies 12 VDC, 500 mA to the unit. Has 2-prong, US non-polarized plug.

DIMENSIONS: 19.0" W x 1.75" H x 8.35" D.
(48.3 x 4.4 x 21.3 cm)

WEIGHT: Approximately 4.5 lbs. (2.1 kg)

WIDE RANGE POWER OPTION AVAILABLE:

(Cat No 517277) **CE, RoHS, and UL** listed table mount power module, 100VAC-240VAC, 50Hz-60Hz for use in place of standard power module that is included with the unit. Has IEC 60320 C14 inlet. **Ideal for international applications.**

Model 7377 Application

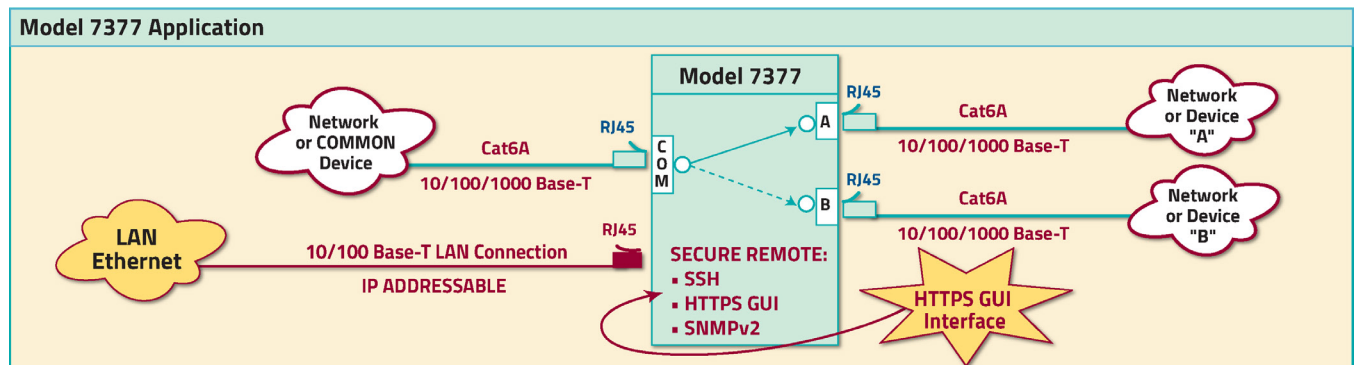

UTILIZING THE HTTPS REMOTE GRAPHICAL USER INTERFACE SOFTWARE

To connect to the switch from a workstation or computer having access to the LAN that the switch's LAN port is connected to, simply launch a standard web browser and type in the URL: `https://<ip address of switch>`

Note that the "s" in "https" is required. The Java Applet will automatically be uploaded from the switch upon connection. The environment requirement for the GUI is Java 1.8_121 or the latest.

CHANGING POSITION AND LOCK STATUS

To change the switch position, click on the radio button "A" or "B" as desired. Locking and unlocking the front panel pushbutton can be done by clicking on the "Locked" or "Unlocked" radio buttons. See Figure 2.

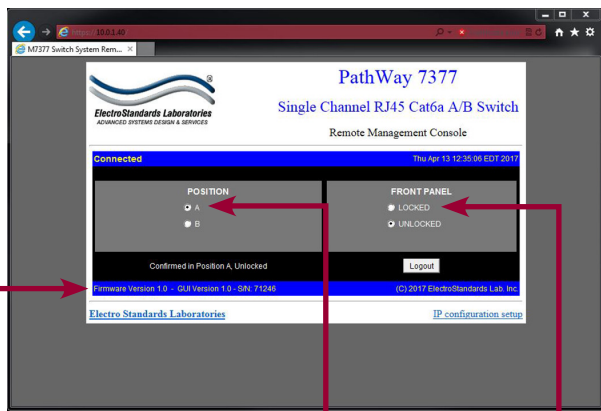

Switch position by selecting "A" or "B".

Lock and unlock the front panel operation.

Figure 2: Change the position and lockout from the GUI

INFORMATION AND IP CONFIGURATION

The Remote Control GUI also provides access to unit information such as the firmware/software version and the serial number. It also provides a link to the Remote Configuration GUI. Note that the Remote Configuration GUI link works regardless of whether the user is logged into the Remote Control GUI or whether the applet loads at all. See Figure 2.

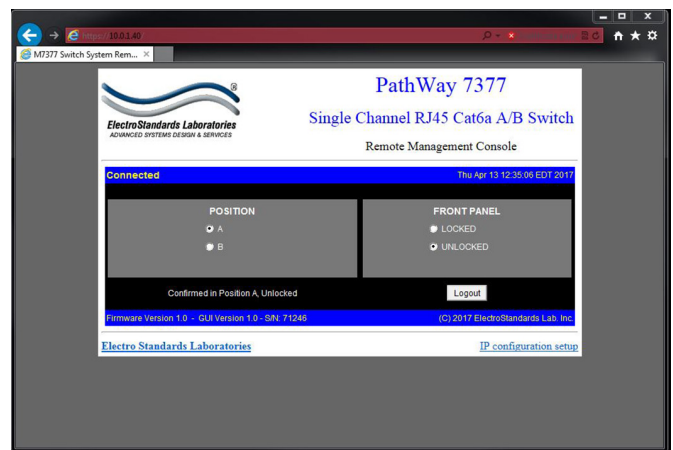
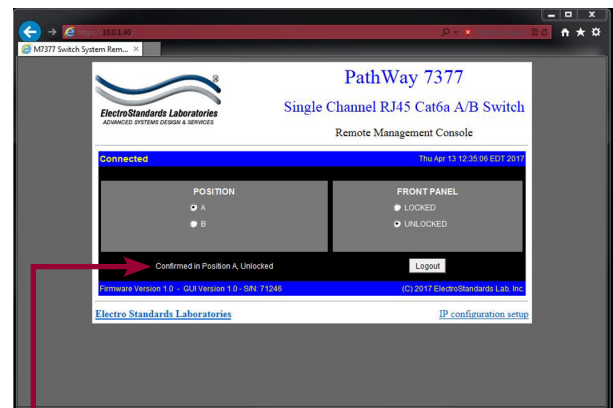

Figure 1: GUI in a Standard Web Browser

QUERYING THE STATUS OF THE UNIT

Once connected, the GUI will stay up-to-date on the present position and status of the unit. Any changes that are made outside of the GUI, such as by pushbutton, will be reflected in the GUI. These changes will cause the radio buttons of the GUI to automatically change to show the new status. The GUI will report the source of the most recent change in the bottom left of the panel. See Figure 3.



"Switch has been changed by pushbutton" GUI is alerted of changes via the front-panel pushbutton operations.

Figure 3: The GUI is alerted to changes in the unit status.