

PathWay® Model 7395 Dual Channel RJ45 Cat6a A/B/C Switch with SSH & HTTPS GUI

- IP Addressable! Communicate with SA Switch via Internet Explorer running a PC.
- Switches all 8 pins. Allows compatibility with all RJ45 interfaeaes.
- Field-proven, high reliability!

INTRODUCTION

The PathWay® Model 7395 Dual Channel Cat6a A/B/C Switch with SSH and HTTPS GUI Remote, allows the user the capability of sharing a single port interface device, connected to the "COMMON" port, among three other devices, connected to the "A", "B" and "C" ports, for each channel. Remote access can be accomplished using an Ethernet 10/100Base-T connection and either SSH commands or Graphical User Interface. The Model 7395 is enclosed in a 1U, full rack size, all metal, black chassis designed to provide EMI/RFI shielding and fit in a standard 19" rack.

Proper authentication is required for Remote access via the 10/100Base-T connection. The user can monitor status and control switch functions.

FEATURES:

- Each channel allows access to three Cat6a RJ45 networks from one COMMON network or device.
- The switch ports are transparent to all data.
- All (8) pins of the RJ45 interface are switched via break-before-make electromechanical relays.
- **Certified Cat6a performance. (10/100/1000 Networks), 10 Gig**
- Unit will switch to the "A" position upon sensing power loss, and continue to pass data.
- Upon the return of power, the unit will remain in the "A" position.
- Simultaneous control of all channels.
- Front panel pushbutton control.
- Control of the switch position from a 10/100Base-T LAN Ethernet environment.
- Remote Control SSH Command Interface or Graphical User Interface that allows the user to control switch position, lockout front panel operations, obtain switch status, as well as query firmware version number, query serial number, and enable/disable autosend of switch positions.
- Remote control of the switch is secured by user login with password protection and TLS/SSL cryptographic protocols.
- Front panel LED's display switch position and power status.



SPECIFICATIONS:

PORT CONNECTORS: (4) RJ45 female connectors labeled A, B, C, and COMMON for each of the two channels.

FRONT PANEL CONTROLS: (3) Manual pushbuttons allow local switching.

DISPLAY: (3) Front panel LED's display switch position and power status.

REMOTE: (1) RJ45 female connector on rear panel accepts Ethernet 10/100 Base-T connection and either TELNET commands or Graphical User Interface for Remote Control operation.

POWER: UL approved wall mount 100VAC-240VAC, 50Hz-60Hz power module supplies 12 VDC, 500 mA to the unit. Has 2-prong, US, non-polarized plug.

DIMENSIONS: Rackmount configuration 19" W x 1.75" H x 10.6" D. (48.3 x 4.4 x 25.6 cm)

WEIGHT: Approximately 4.6 lbs (2.7 1kg)

WIDE RANGE POWER OPTION AVAILABLE:

(Cat No 517277) **CE, RoHS, and UL** listed table mount power module, 100VAC-240VAC, 50Hz-60Hz for use in place of standard power module that is included with the unit. Has IEC 60320 C14 inlet. **Ideal for international applications.**

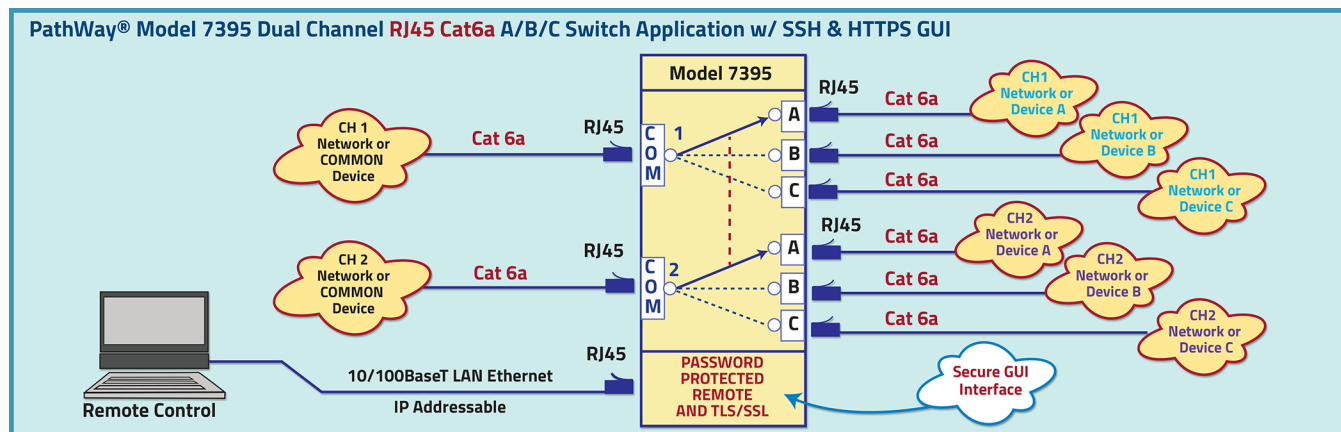

UTILIZING THE HTTPS REMOTE GRAPHICAL USER INTERFACE SOFTWARE

To connect to the switch from a workstation or computer having access to the LAN that the switch's LAN port is connected to, simply launch a standard web browser and type in the URL: `https://<ip address of switch>`

Note that the "s" in "https" is required. The Java Applet will automatically be uploaded from the switch upon connection. The environment requirement for the GUI is Java 1.7u40 or the latest.

SOFTWARE FEATURES:

- Access User Interface via standard web browser.
- Login password authentication required.
- **Easy to use, simple point and click operation.**
- Remotely access to control or monitor the Model 7395 Dual RJ45 A/B/C Switch System with SSH and HTTPS GUI
- Users can change the login password and/or the switch's IP address.
- LAN access gives users access across the LAN or over the Internet access to control if user network is configured accordingly.

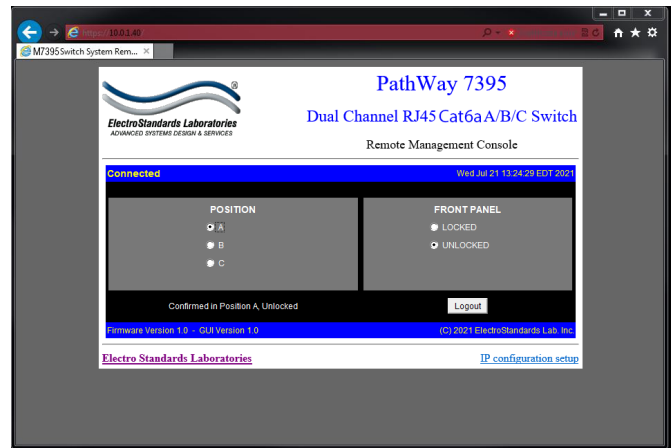
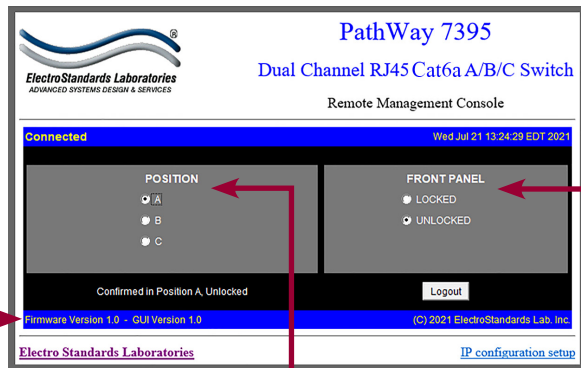

Figure 1: GUI in a Standard Web Browser

CHANGING POSITION AND LOCK STATUS

To change the switch position, click on the radio button "A", "B" or "C" as desired. Locking and unlocking the front panel pushbutton can be done by clicking on the "Locked" or "Unlocked" radio buttons. See Figure 2.



Switch position by selecting "A", "B", or "C".

Lock and unlock the front panel operation.

Figure 2: Change the position and lockout from the GUI

INFORMATION AND IP CONFIGURATION

The Remote Control GUI also provides access to unit information such as the firmware/software version and the serial number. It also provides a link to the Remote Configuration GUI. Note that the Remote Configuration GUI link works regardless of whether the user is logged into the Remote Control GUI or whether the applet loads at all. See Figure 2.

QUERYING THE STATUS OF THE UNIT

Once connected, the GUI will stay up-to-date on the present position and status of the unit. Any changes that are made outside of the GUI, such as by pushbutton, will be reflected in the GUI. These changes will cause the radio buttons of the GUI to automatically change to show the new status. The GUI will report the source of the most recent change in the bottom left of the panel. See Figure 3.

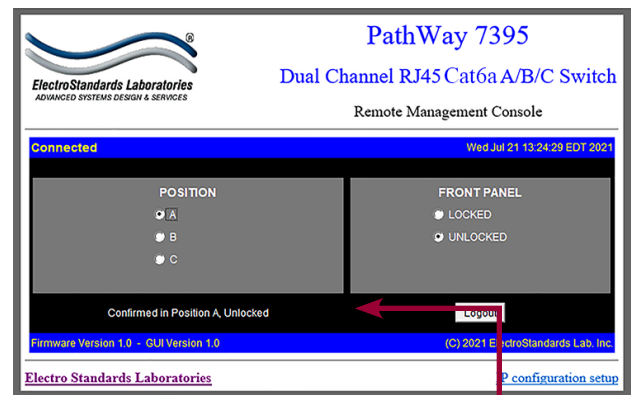

Confirmed in Position A, Unlocked (switched by pushbutton)"

GUI is alerted of changes via the front-panel pushbutton operations.

Figure 3: The GUI is alerted to changes in the unit status.