

PathWay® Model 7400 9-Channel A/B Multi-Interface Switch: (3) 4-Pin 3.5mm Audio, (3) RJ45 Cat5e, and (3) HDMI Video with RS232 Remote

- *Quickly and easily switch all nine channels (Data, Audio, and Video) simultaneously!*
- *Ideal for conference room applications that require switching video cameras to codec or display units.*
- *Ideal for conference room applications that employ smart cameras having an HDMI Video Channel, an Ethernet port to control camera movement, an audio port for integrated sound.*

INTRODUCTION

The PathWay® Model 7400 9-Channel A/B Multi-Interface Switch: (3) RJ45 Cat5e, (3) 4-Pin 3.5 mm, and (3) HDMI with RS232 Remote allows the user the capability of sharing a single port RJ45 Cat5e, 3.5mm, and HDMI interface device, connected to the "COMMON" port, among two other devices, connected to the "A" and "B" ports. The Model 7400 is enclosed in a 2U, full rack size, all metal, black chassis designed to provide EMI/RFI shielding and fit in a standard 19" rack.

The switch may be controlled manually via a front panel pushbutton or remotely from an RS232 Serial port located on the rear of the unit. Switch position status may be attained via the front panel LED display or the Remote RS232 Serial port located on the rear of the unit.

FEATURES:

- Simultaneously switch all nine channels via a front panel pushbutton.
- The switch ports are transparent to all data.
- All (8) pins of the RJ45 Data interface are switched via break-before-make electromechanical relays.
- All (4) leads of the 4-Pin 3.5mm Audio Interface are switched via break-before-make electromechanical relays.
- All (19) pins of the HDMI Video interface are switched via break-before-make electromechanical relays.
- The unit maintains last set position on power loss and continues to pass data for the 3.5mm and RJ45 Cat5 ports.
- On power loss, the HDMI Video Channels remain in present position, but shut down and do not pass signals.
- Upon power up, switch remains in last known position.
- Front panel pushbutton control.
- Remote RS232 ASCII commands that allow the user to control switch position, lockout front panel operations, obtain switch status, query firmware version number, query serial number, and enable/disable autosend of switch positions.
- Simultaneous control of channels.
- Front panel LED's display the present position and power status.
- **Certified for Cat 5e compliance.**
- **Certified for POE 802.3af & 802.3at compliance.**
- **HDMI supports 1080p.**



SPECIFICATIONS:

PORT CONNECTORS:

- (9) RJ45 Cat5e female connectors; three labeled A, B, and COMMON for each channel
- (9) 4-Pin 3.5mm connectors; three labeled, A, B, and COMMON for each channel.
- (9) HDMI connectors; three labeled, A, B, and COMMON for each channel.

FRONT PANEL CONTROL: (1) Manual Pushbutton allows local switching.

DISPLAY: (2) Front panel LED's display switch position and power status.

REMOTE PORT: (1) DB9 female connector on rear panel accepts RS232 Serial Data for Remote Control operation

POWER: UL approved wall mount 100VAC-240VAC, 50Hz-60Hz power module supplies 12 VDC, 500 mA to the unit. Has 2-prong, US, non-polarized plug

DIMENSIONS: 19.0"W x 3.5"H x 10.2"D.
(48.3 x 8.9 x 26.0 cm)

WEIGHT: Approx. 6.8 lbs. (3.1 kg)

WIDE RANGE POWER OPTION AVAILABLE:

(Cat No 517277) **CE, and UL** listed table mount power module, 100VAC-240VAC, 50Hz-60Hz for use in place of standard power module that is included with the unit. Has IEC 60320 C14 inlet. **Ideal for international applications.**

PathWay® Model 7400 9-Channel A/B Multi-Interface Switch: (3) 4-Pin 3.5mm Audio, (3) RJ45 Cat5e, and (3) HDMI Video with RS232 Remote

- *Quickly and easily switch all nine channels (Data, Audio, and Video) simultaneously!*
- *Ideal for conference room applications that require switching video cameras to codec or display units.*
- *Ideal for conference room applications that employ smart cameras having an HDMI Video Channel, an Ethernet port to control camera movement, an audio port for integrated sound.*

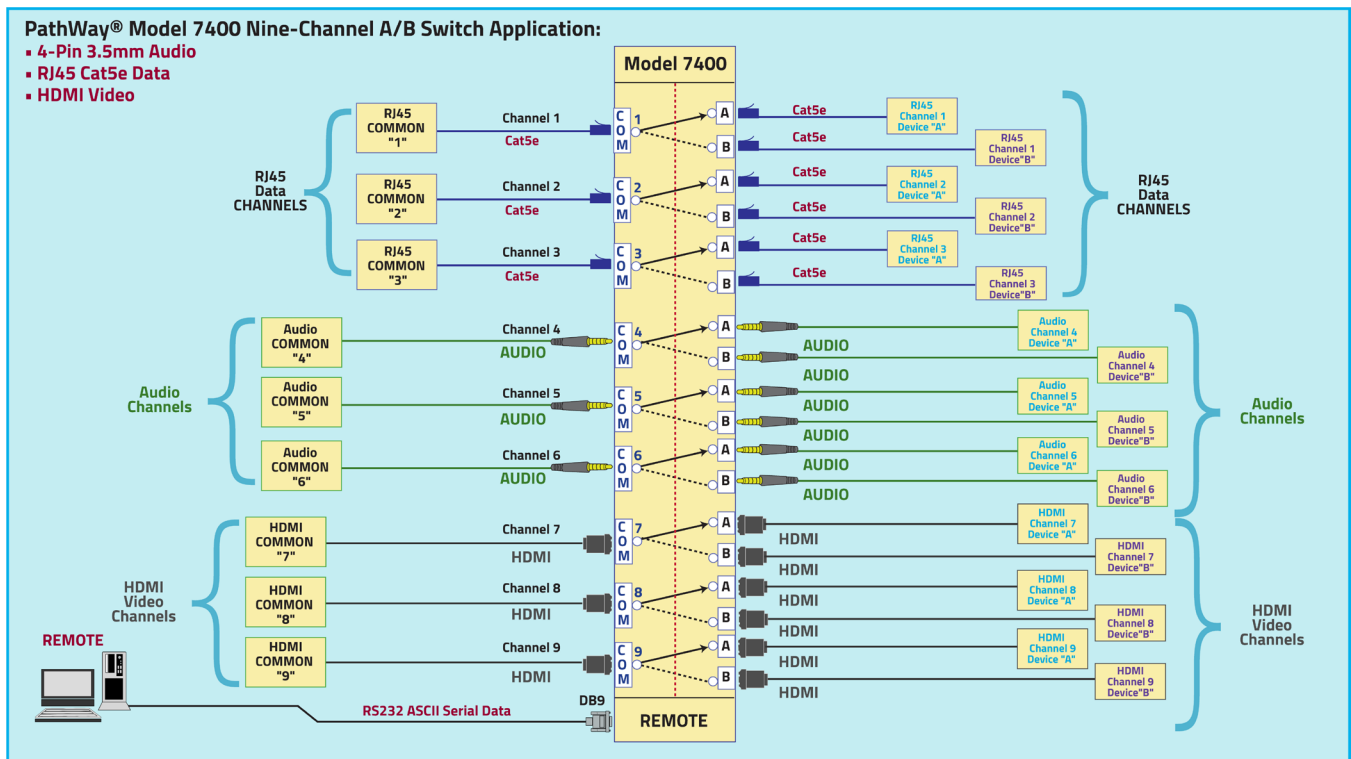

CUSTOMER & TECHNICAL SUPPORT

CUSTOMER SUPPORT

For customer assistance, ordering assistance, or communications cables of any length or configuration, please contact Electro Standards Laboratories, (877) 943-1164 and ask for sales/customer support.

TECHNICAL SUPPORT

For technical support with unit operation, cable configuration, etc., please contact Electro Standards Laboratories, (877) 943-1164 and ask for technical support. Please have the unit model number and serial number available when you call.