

LineSelect® Model 8443 Dual-Channel RJ45/BNC A/B Switch, Manual Operation

- Simultaneously Switches 1 Channel RJ45 (Cat5e) and 1 Channel BNC (RG59, 75 Ohm)
- Increases network efficiency by facilitating sharing of peripherals!
- Field Proven, Highly Reliable!

INTRODUCTION

The **LineSelect®** Model 8443 Dual-Channel RJ45/BNC A/B Switch enables access to two devices per each of its two channels. Channel 1 allows access to RJ45 devices 1-A or 1-B. Channel 2 allows access to BNC devices 2-A or 2-B. All channels are switched simultaneously. The unit supports 8 pins for the RJ45 Cat5 interface, and supports both the center conductor and shield of the BNC interface. The **LineSelect®** Model 8443 is enclosed in a slim desktop style enclosure.

FEATURES:

- Simultaneously switches one RJ45 Channel and one BNC channel locally via a knob located on the front panel
- **RJ45 channel tested for Cat5e compliance**
- All (8) pins of the RJ45 interface are switched via break-before-make rotary switch.
- Both the shield and center conductor of the 75 Ohm coax interface are switched via break-before-make rotary switch.
- All ports located on the rear panel: (3) RJ45 female and (3) BNC female
- Attractive anodized black box packaging provides EMI/RFI shielding.
- Switching is manually operated. Requires no power.
- Custom length cables are available for optimum performance. Choose Length in feet.



SPECIFICATIONS:

Port Connectors:

(3) RJ45 (F), Cat 5e connectors on rear panel
(3) BNC (F) Connectors on rear panel. (75 Ohm)

Controls: (1) Rotary Switch on front panel selects A or B.

Pins Switched:

RJ45: All 8 Pins Switched.
BNC: Center Conductor and Shield

Power: No power required.

Enclosure: Desktop Aluminum Enclosure.

Dimensions: 5.25"W x 2.0"H x 7.25"D. (20.6 x 7.2 x 20.4 cm)

WEIGHT: 2.85 lbs (0.8 kg)

LineSelect® Model 8443 Dual-Channel RJ45/BNC A/B Switch Application

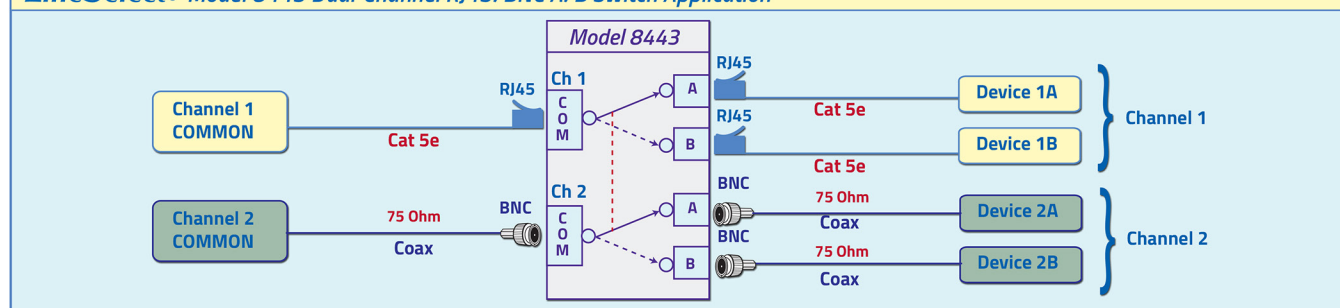

Suggested cables for use with Model 8443 Switch. Specify the length in feet when ordering.

Part Number	Description	Price (USD)
990137-006	M/M, 75 ohm, BNC Coaxial Cable, PVC, 6-Feet	Call for Price!
990137-010	010 Feet, M/M, 75 ohm, BNC Coaxial Cable, PVC, 10 Feet	Call for Price!
990137-Length	Choose Custom Length in Feet, M/M, 75 ohm, BNC Coaxial Cable, PVC	Call for Price!