



Electro Standards Laboratories
ADVANCED SYSTEMS DESIGN & SERVICES



SPECIFICATIONS
MODEL 9251
(Cat. No. 309251)

LineSelect® Model 9251 Dual-Channel Switch, RS530 DB25 A/B/C/D and DB25 A/B, Manual, Rackmount

- **Applicable to Switching ANY DB25 interface devices.**

INTRODUCTION

The **LineSelect®** Model 9251 Switch system is comprised of two independent sharing switches efficiently packaged in a 19-inch wide 2U high (3.5") rackmount unit. The switch functions are described and illustrated below.

FEATURES:

- Independently switch each of the two channels manually via two knobs located on the front panel, one knob per channel.
- **Channel 1:** DB25 A/B/C/D Switch with (5) DB25 female connectors for ports "A", "B", "C", "D" and "Common".
- **Channel 2:** DB25 A/B Switch with (3) DB25 female connectors for ports "A", "B" and "Common".
- **All 25 pins of the RS530 interface are switched via break-before-make rotary switch.**
- High reliability, precious metal, sealed switches.
- Transparent to data speed and format.
- Eliminates the need to plug and unplug cables.
- All ports located on rear panel.
- Manual operation. No power required.
- Attractive all metal black box packaging provides EMI/RFI shielding.
- Custom length DB25 cables are available for your switch installation.
- **Lifetime warranty against manufacturing defects.**



SPECIFICATIONS:

CHANNEL-1 PORT CONNECTORS: (5) DB25 female connectors labeled A, B, C, D, and COMMON.
CHANNEL-2 PORT CONNECTORS: (3) DB25 female connectors labeled A, B, and COMMON.
FRONT PANEL CONTROLS: (2) Manual rotary switches allow local switching.
DIMENSIONS: Rackmount 19.0" W x 3.5" H x 8.0" D. (48.3 x 8.9 x 20.3 cm)
WEIGHT: Approximately 6.0 lbs. (2.72 kg)

Ask about our popular

Model 900
EIA/TIA RS-530
Interface Analyzer
Red and Green light emitting diodes indicate status of key signals at the EIA/TIA data interface. Easy to use for fault isolation.



LineSelect® Model 9251 Dual-Channel Switch, RS530 DB25 A/B/C/D & DB25 A/B Switch

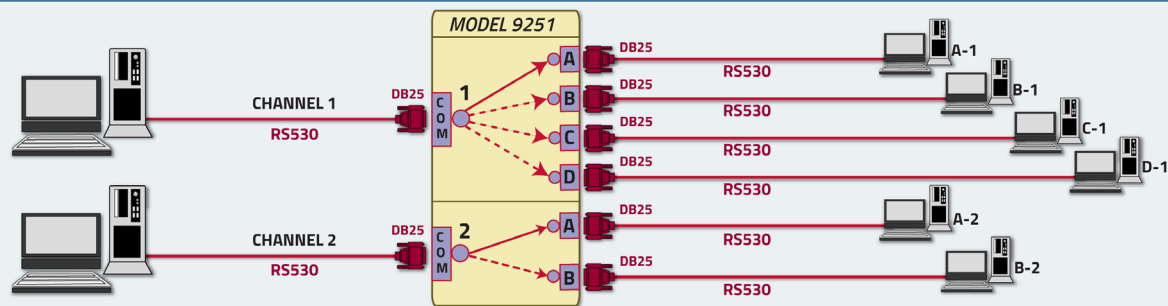

Custom length data network cables 25-conductor, DB25/DB25, Unshielded, PVC.

Part Number	Connectors	Length Specify XXX-FT	Price (USD)
990104-XXX	F/F	XXX-FT	\$24.00 + 0.55 / FT
990105-XXX	M/F	XXX-FT	\$24.00 + 0.55 / FT
990106-XXX	M/M	XXX-FT	\$24.00 + 0.55 / FT

36 Western Industrial Drive, Cranston, RI 02921
Tel: 401-943-1164 Fax: 401-946-5790

www.ElectroStandards.com
E-mail: eslab@ElectroStandards.com